



零件手册

PARTS CATALOG

Model

EK40

Spec.No.

Spec.Name.

EK400BC7010

标准型

EK400BC7020

长油箱（红）/横置排气管

EK400BC7030

长油箱（黑）/横置排气管

EK400BC7040

标准型/充电款

EK400BC7050

长油箱（红）/充电款

EK400BC7060

长油箱（黑）/充电款

常州富士常柴罗宾汽油机有限公司

1. 曲轴箱组 CRANK CASE

FIG.100

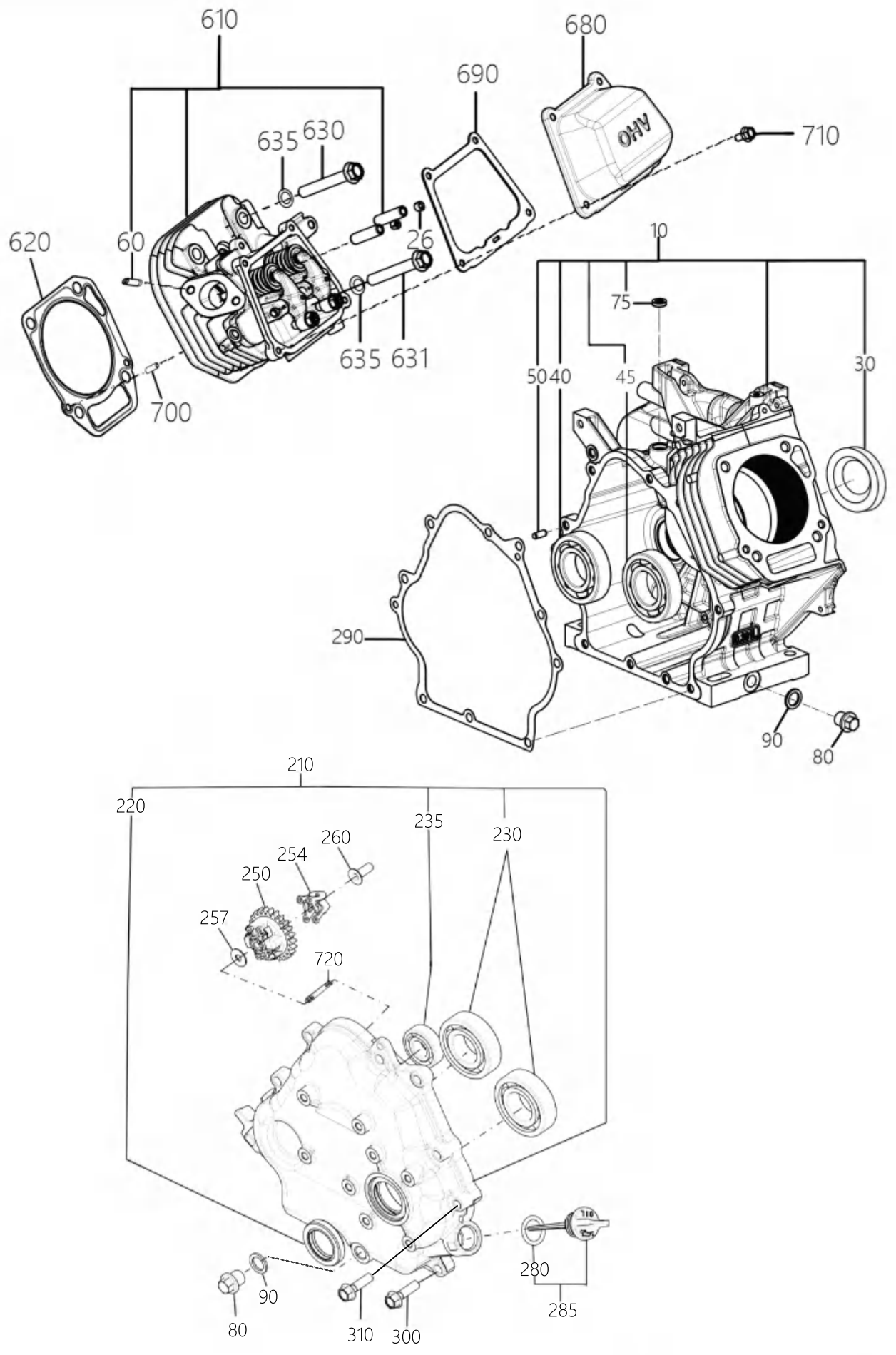

1. 曲轴箱组..... CRANK CASE

指示序号 REF.NO.	零部件代号 PART NUMBER	零部件名称 PART NAME	数量 QTY	备注 REMARKS	图示代号 FIG.NO.
10	40D-10102-H2	曲轴箱组件 CRANKCASE CP	1		100
26	40D-16011-H3	密封圈 STEM SEAL	1		100
30	X44-03500-20	油封 OIL SEAL	1		100
40	X60-01701-00	深沟球轴承 BALL BEARING	1		100
45	X60-03501-00	深沟球轴承 BALL BEARING	1		100
50	X31-00600-50	定位销 DOWEL PIN	2	6DX14.8L	100
60	X10-50806-00	双头螺栓 STUD	2		100
75	X44-00800-20	油封 OIL SEAL	1		100
80	20F-11400-30	放油螺塞 PIUG	3	M14X12L	100
90	X21-11400-31	平垫 GASKET	3		100
210	40D-10901-H1	主轴承盖组件 MAINBEARING COVER CP	1		100
220	X44-03000-30	油封 OIL SEAL	1		100
230	X60-03001-00	深沟球轴承 BALL BEARING	2		100
235	X60-01701-00	深沟球轴承 BALL BEARING	1		100
250	40D-45001-H1	调速齿轮组件 GOVERNOR GEAR CP	1		100
254	40D-4160-H3	甩块 FLYWEIGHT	2		100
257	X03-11060-10	垫圈 WASHER	1		100
260	40D-41901-H3	滑套 GOVERNOR SLEEVE	1		100
280	40D-69908-H3	O型圈 O RING	2		100
285	40D-63601-H1	油尺组件 OIL GAUGE CP	2		100
290	40D-16001-H3	主轴承盖垫片 GASKET(M.B.COVER)	1		100
300	X11-00805-90	法兰螺栓 FLANGE BOLT	8	M8X30L	100
310	X11-00805-40	法兰螺栓 FLANGE BOLT	2	M8X40L	100
610	40D-13001-H1	汽缸盖组件 CYLINDER HEAD CP	1		100
620	40D-15001-H3	汽缸盖垫片 GASKET(HEAD)	1		100
630	X11-01001-30	法兰螺栓 FLANGE BOLT	2	M10X65L	100
631	X11-01001-30	法兰螺栓 FLANGE BOLT	2	M10X65L	100
635	22A-19910-03	垫圈 WASHER	4		100
680	40D-15501-H1	摇臂盖组件 ROCKER COVER CP	1		100
690	40D-16002-H3	摇臂盖垫片 GASKET(ROCKER COVER)	1		100
700	X31-00600-50	定位销 DOWER PIN	2	6DX14.8L	100
710	20F-00600-21	法兰螺栓 FLANGE BOLT	4	M6X12L	100
720	40D-46201-H3	调速器齿轮轴 GOVERNOR GEAR SHAFT	1		100
960	40D-99001-H7	垫片组 GASKET SET	1		100
		垫片组包含: FIG: 100: 290. 620. 690; FIG: 300:530. 550. 560; FIG: 330: 340			
		INCL: FIG: 100: 290. 620. 690; FIG: 300:530. 550. 560; FIG: 330: 340			

2. 曲柄活塞组 CRANK,PISTON

FIG.200

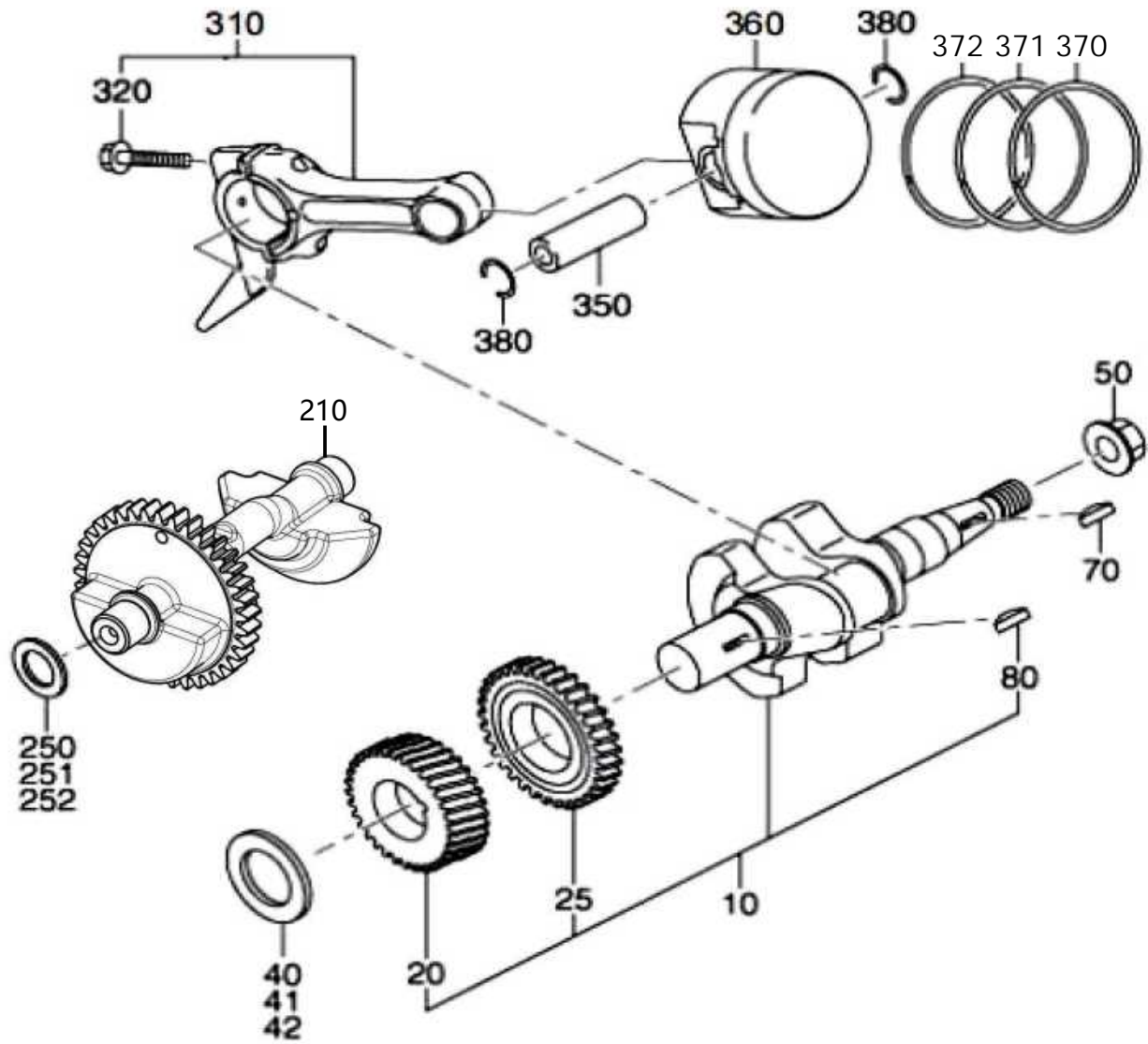

2. 曲柄活塞组 CRANK, PISTON

指示序号 REF.NO.	零部件代号 PART NUMBER	零部件名称 PART NAME	数量 QTY	备注 REMARKS	图示代号 FIG.NO.
10	40D-20101-H1	曲轴组件 CRANK SHAFT CP	1		200
20	40D-22301-H3	曲轴齿轮 CRANK SHAFT GEAR	1		200
25	40D-24201-H3	平衡齿轮 BALANCER GEAR	1		200
40	X23-03002-50	调整垫片 SPACER	1	T=0.2	200
41	X23-03002-90	调整垫片 SPACER	1	T=0.4	200
42	X23-03003-70	调整垫片 SPACER	1	T=0.8	200
50	X18-01400-30	法兰螺母 FLANGE NUT	1		200
70	X32-30501-70	半月键 WOODRUFF KEY	1		200
80	X32-30501-70	半月键 WOODRUFF KEY	1		200
210	40D-24101-H3	平衡轴 BALANCER SHAFT	1		200
250	X23-02020-20	调整垫片 SPACER	1	T=0.2	200
251	X23-02020-40	调整垫片 SPACER	1	T=0.4	200
252	X23-02020-60	调整垫片 SPACER	1	T=0.6	200
310	40D-22501-H0	连杆组合 CONNECTING ROD AY	1		200
320	40D-23001-H3	连杆螺栓 CONNECTING ROD BOLT	2		200
350	40D-23301-H3	活塞销 PISTON PIN	1		200
360	40D-23401-H3	活塞 PISTON	1		200
370	40D-23601-H3	头环 TOP RING	1		200
371	40D-23701-H3	二环 SECOND RING	1		200
372	40D-23901-H1	油环 OIL RING CP	1		200
380	X56-51801-00	卡簧 CLIP	2		200

3. 进、排气组 INTAKE EXHAUST

FIG.300

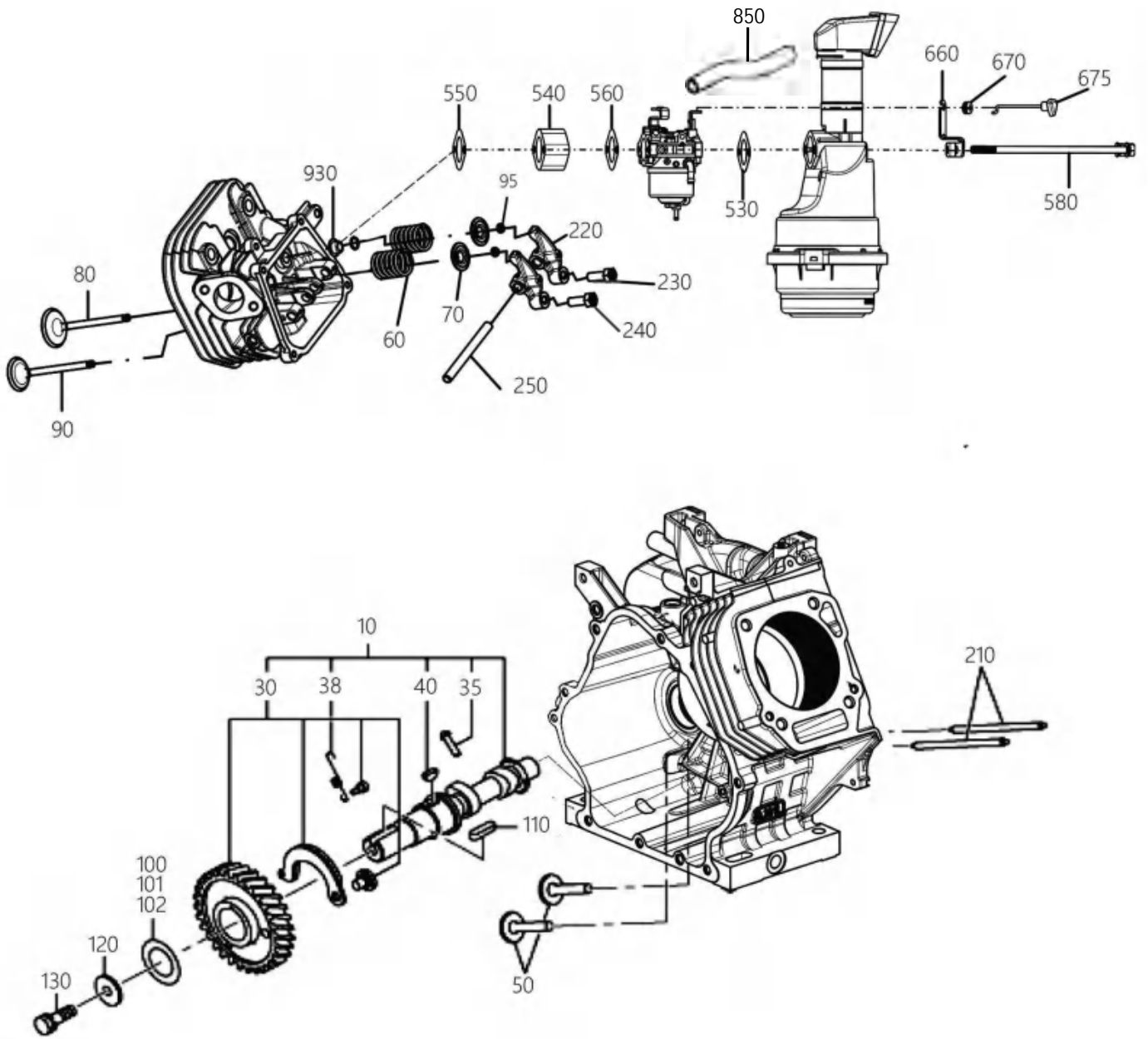

3. 进、排气组·····INTAKE EXHAUST

指示序号 REF.NO.	零部件代号 PART NUMBER	零部件名称 PART NAME	数量 QTY	备注 REMARKS	图示代号 FIG.NO.
10	40D-31601-H1	凸轮轴组件 CAM SHAFT CP	1		300
30	40D-33201-H1	凸轮轴齿轮组件 CAM SHAFT GEAR CP	1		300
35	40D-36803-H3	减压滑销 PIN(DECOMP)	1		300
38	22D-36701-H3	回位弹簧 RETURN SPRING	1		300
40	X32-30501-70	半月键 WOODRUFF KEY	1		300
50	40D-33301-H3	挺柱 TAPPET	2		300
60	40D-33601-H3	气门弹簧 VALVE SPRING	2		300
70	40D-33701-H3	弹簧座圈 SPRING RETAINER	2		300
80	40D-33401-H3	进气门 INTAKE VALVE	1		300
90	40D-33501-H3	排气门 EXHAUST VALVE	1		300
95	40D-35501-H3	气门锁夹 COLLET VALVE	4		300
100	X23-03002-50	调整垫片 SPACER	1		300
101	X23-03002-90	调整垫片 SPACER	1	T=0.2	300
102	X23-03002-70	调整垫片 SPACER	1		300
110	X32-30501-70	平键 KEY	1		300
120	X20-00800-20	垫圈 WASHER	1		300
130	X13-00802-50	螺栓/平垫组合 BOLT AND WASHER AY	1	M8X10L	300
210	40D-35301-H1	推杆 PUSH ROD CP	2		300
220	40D-36001-H3	摇臂 ROCKER ARM	2		300
230	40D-36301-H3	调整螺栓 ADJUSTING SCREW	2		300
240	40D-39903-H3	调整螺母 NUT	2		300
250	40D-35001-H3	摇臂轴 ROCKER SHAFT	1		300
530	40D-35903-H3	空滤垫片 GASKET(CLEANER)	1		300
540	40D-32901-H3	绝热垫 INSULATOR	1		300
550	40D-35902-H3	垫片(绝热垫) GASKET(INSULATOR)	1		300
560	40D-35902-H3	垫片(绝热垫) GASKET(INSULATOR)	1		300
580	X13-00803-20	法兰螺栓 FLANGE BOLT	2	M8X160L	300
660	40D-47101-H3	支架 BRACKET	1		300
670	X24-10200-50	橡胶套 GROMMET	1		300
675	40D-44001-H1	阻风门手柄 CHOKE KNOB CP	1		300
850	40D-18003-H3	通气软管 BREATHER PIPE	1		300
930	40D-16011-H3	油封 STEM SEAL	1		300

3. 进、排气组·····INTAKE EXHAUST

FIG.317

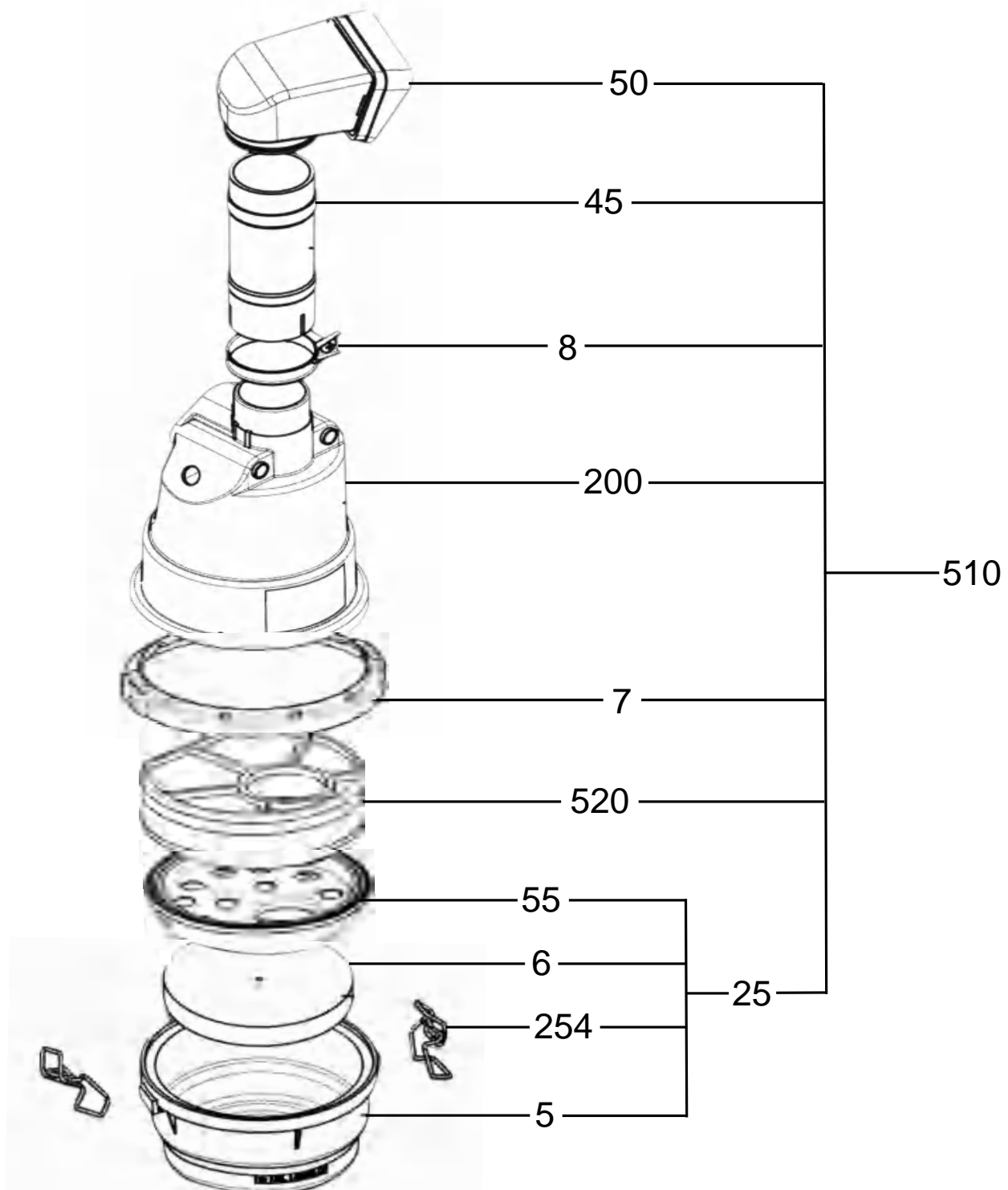

3. 进、排气组·····INTAKE,EXHAUST

指示序号 REF.NO.	零部件代号 PARTNUMBER	零部件名称 PART NAME	数量 QTY	备注 REMARKS	图示代号 FIG.NO.
510	40D-32603-H0	空滤器总成 AIR CLEANER AY	1		317
-5	40D-32603-H0-12	油底杯 OILPAN	1		317
-6	40D-32603-H0-11	油杯海绵 FOAM RUBBER	1		317
-7	40D-32603-H0-8	搭扣支架 BRACKET	1		317
-8	40D-32603-H0-4	卡箍 BAND(AIR/C)	1		317
-25		机油滤杯组件 OILPAN ASSY	1		317
-45	40D-32603-H0-3	进气管 JOINT	1		317
-50	40D-32603-H0-2	进气弯管 CAP,COMP	1		317
-55	40D-32603-H0-10	挡油板 DUMPER(OILPAN)	1		317
-200	40D-32603-H0-5	空滤壳体 BODY,COMP	1		317
-254	40D-32603-H0-7	搭扣 CILP	2		317
-520	40D-32603-H0-6	滤芯组合 ELEMENT ASSY	1		317

3. 进、排气组·····INTAKE EXHAUST

FIG.330

横置排气管

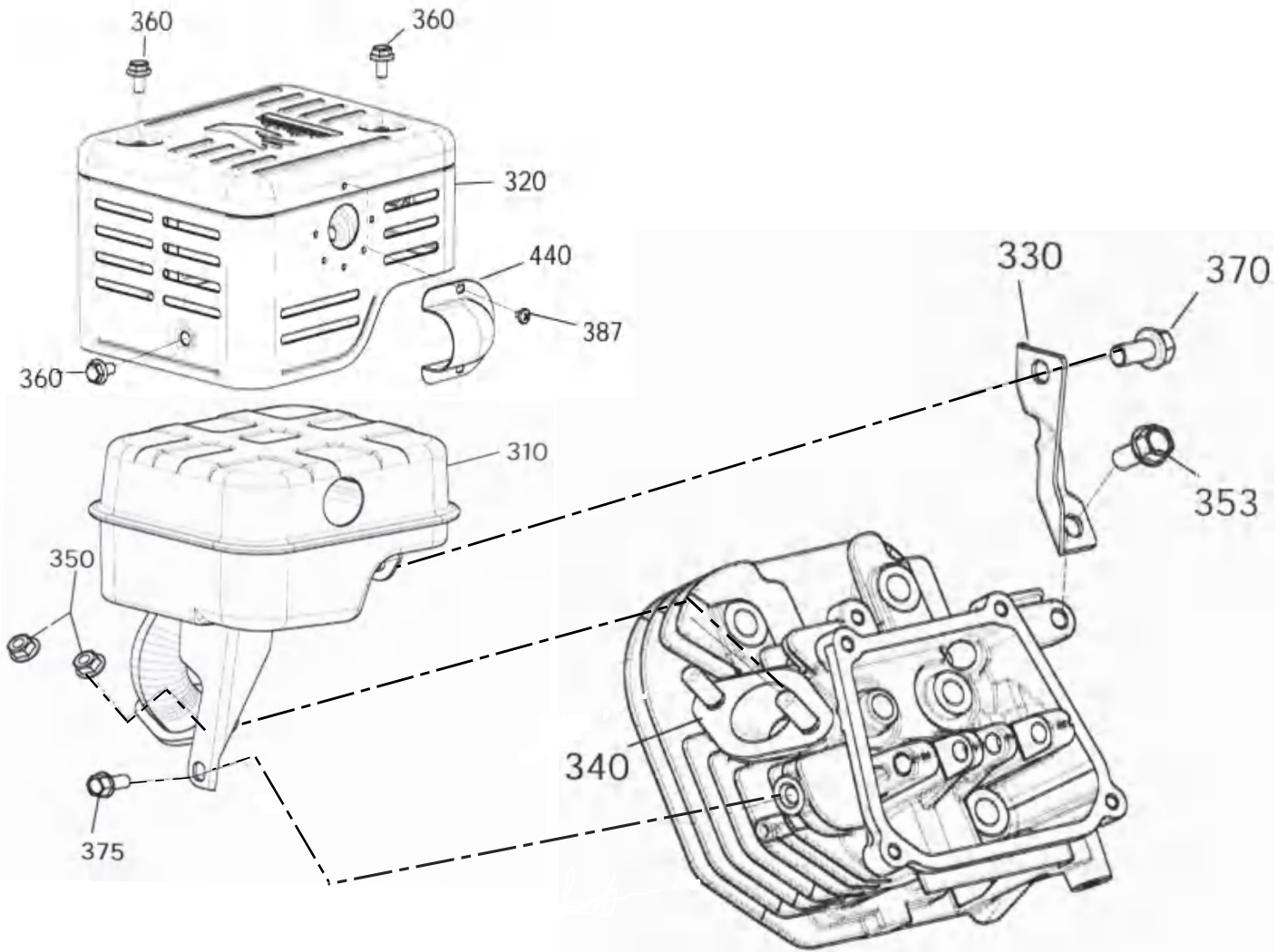
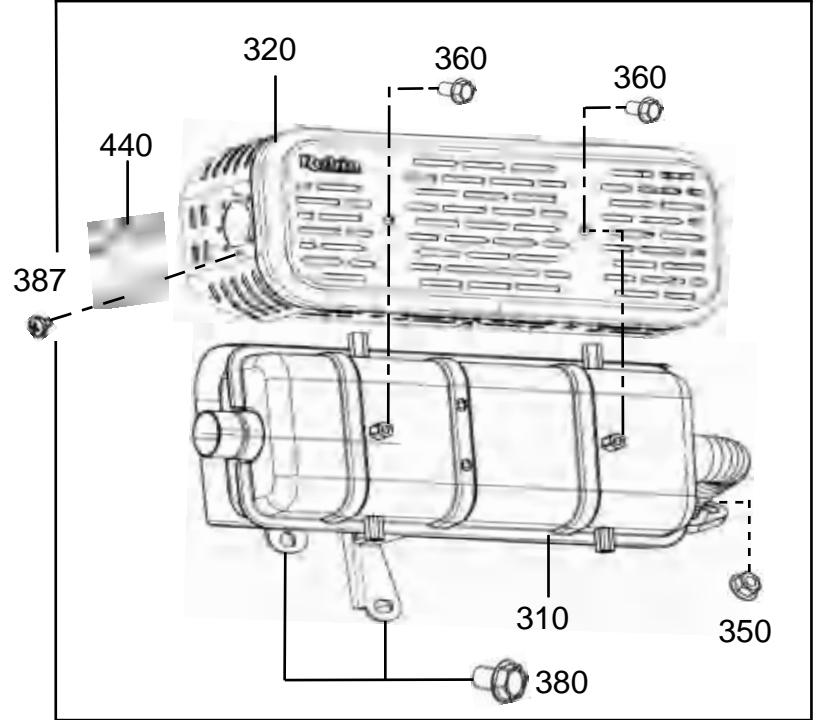

3. 进、排气组·····INTAKER,EXHAUST

指示序号 REF.NO.	零部件代号 PART NUMBER	零部件名称 PART NAME	数量 QYT	备注 REMARKS	图示代号 FIG.NO.
310	40D-30101-H2	消音器组件 MUFFLER UN	1		330
	40D-30201-H1	消音器组件 MUFFLER UN	1	横置排气管	330
320	40D-34201-H1	消音器罩组件 MUFFLER COVER CP	1		330
	40D-34221-H1	消音器罩组件 MUFFLER COVER CP	1	横置排气管罩	330
330	40D-37001-H3	消音器支架 BRACKET(MUFFLER)	1		330
340	40D-35201-H3	消音器垫片 GASKET(MUFFLER)自	1		330
350	X17-60800-20	锁螺母 SELF LOCK NUT	2	M8	330
353	20F-04081-60	法兰螺栓 FLANGE BOLT	1	M8X16L	330
360	X13-00601-00	法兰螺栓 FLANGE BOLT	4	M6X8L	330
	X13-00601-00	法兰螺栓 FLANGE BOLT	6	M6X8L 横置用	330
370	20F-04081-60	法兰螺栓 FLANGE BOLT	1	M8X16L	330
375	20F-04081-60	法兰螺栓 FLANGE BOLT	1	M8X16L	330
380	X11-00805-00	法兰螺栓 FLANGE BOLT	2	M8X18L	330
387	X15-00401-20	自攻螺钉 TAPPING SCREW	3	ST4X6L	330
440	22D-37103-J1	偏向器 DEFLECTOR CP	1		330

4. 调速系统组 GOVERNOR

FIG.400

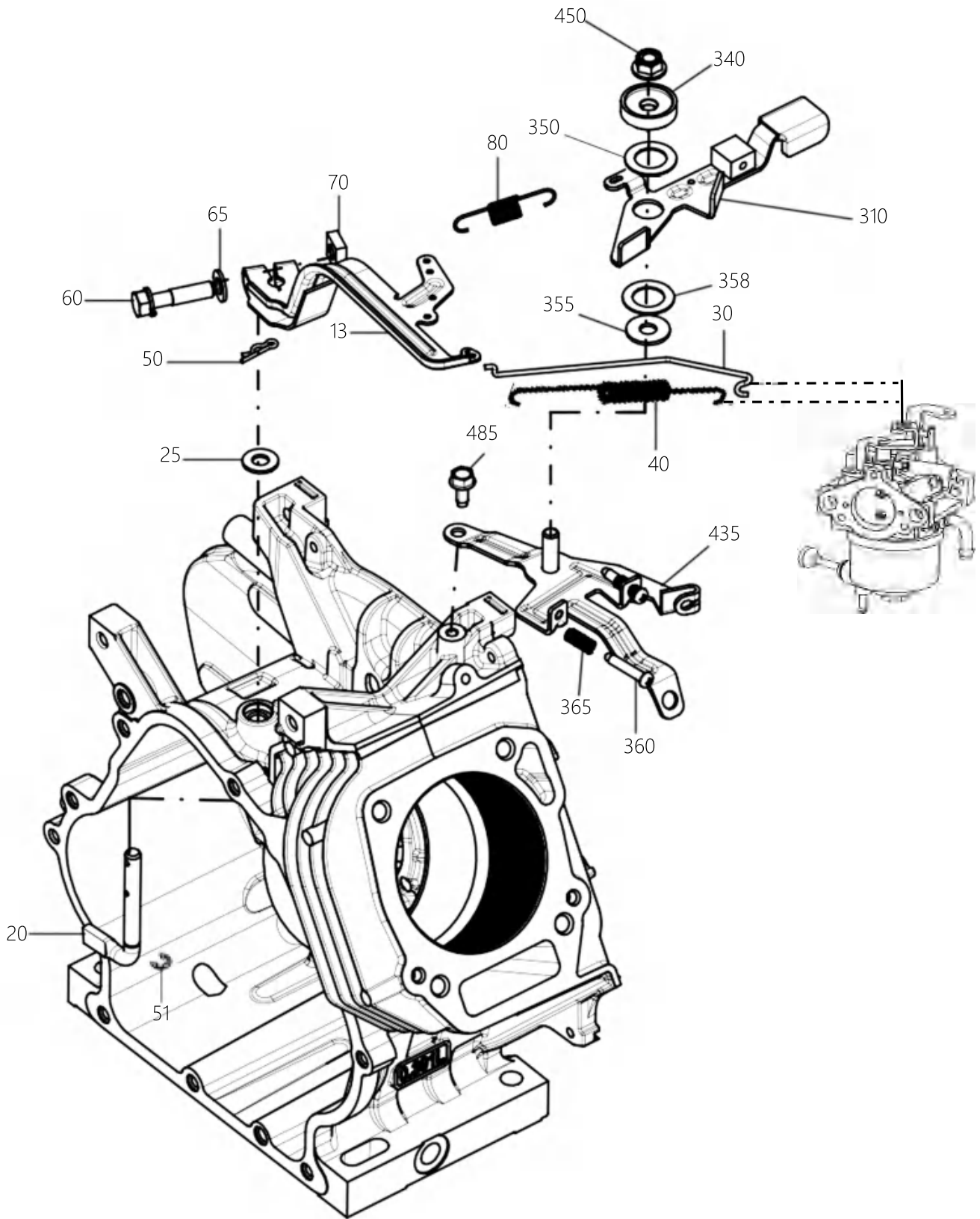

4. 调速系统组· · · · · GOVERNOR

指示序号 REF.NO.	零部件代号 PART NUMBER	零部件名称 PART NAME	数量 QTY	备注 REMARKS	图示代号 FIG.NO.
13	40D-42302-H0	调速器杆组件 GOVERNOR LEVER CP	1		400
20	40D-42203-H3	调速器轴 GOVERNOR SHAFT	1		400
25	20F-11080-00	平垫 WASHER	1		400
30	40D-42701-H3	调速器拉杆 GOVERNOR ROD	1		400
40	40D-42801-H3	拉杆弹簧 ROD SPRING	1		400
50	X30-10800-20	开口销 SNAP PIN	1		400
51	003-13060-00	卡簧 CLIP	1	6DX12DX0.8T	400
60	X13-00802-70	螺栓/平垫组合 BOLT AND WASHER AY	1	M8	400
65	20F-00802-20	平垫 WASHER	1	T=1.2	400
70	X18-60800-10	方形螺母 NUT	1	M8	400
80	40D-42501-H3	调速器弹簧 GOVERNOR SPRING	1		400
310	40D-43304-H1	速控器组件 SPEED CONT.LEVER CP	1		400
340	22D-49901-H3	项圈 PLATE(PRESSURE)	1		400
350	22A-49903-03	波形垫片 WAVED WASHER	1		400
355	X20-10802-40	平垫 WASHER	1	T=1.6	400
358	22D-49902-H3	基座 COLLAR	1		400
360	X14-00501-10	调速螺钉 SCREW	2	M5X27L	400
365	X83-00000-20	压簧 COIL SPRING	2		400
435	40D-46502-H1	支架组件 BRACKET CP(SPD CTL)	1		400
440	X14-00501-20	线夹螺钉 SCREW	1	M5X8L	400
450	X17-60800-40	自锁螺母 SELF LOCK NUT	1	M8	400
485	20F-13061-60	螺栓/平垫组合 BOLT AND WASHER AY	1	M6X14L	400

5. 冷却, 启动组..... COOLING, STARTING

FIG.500

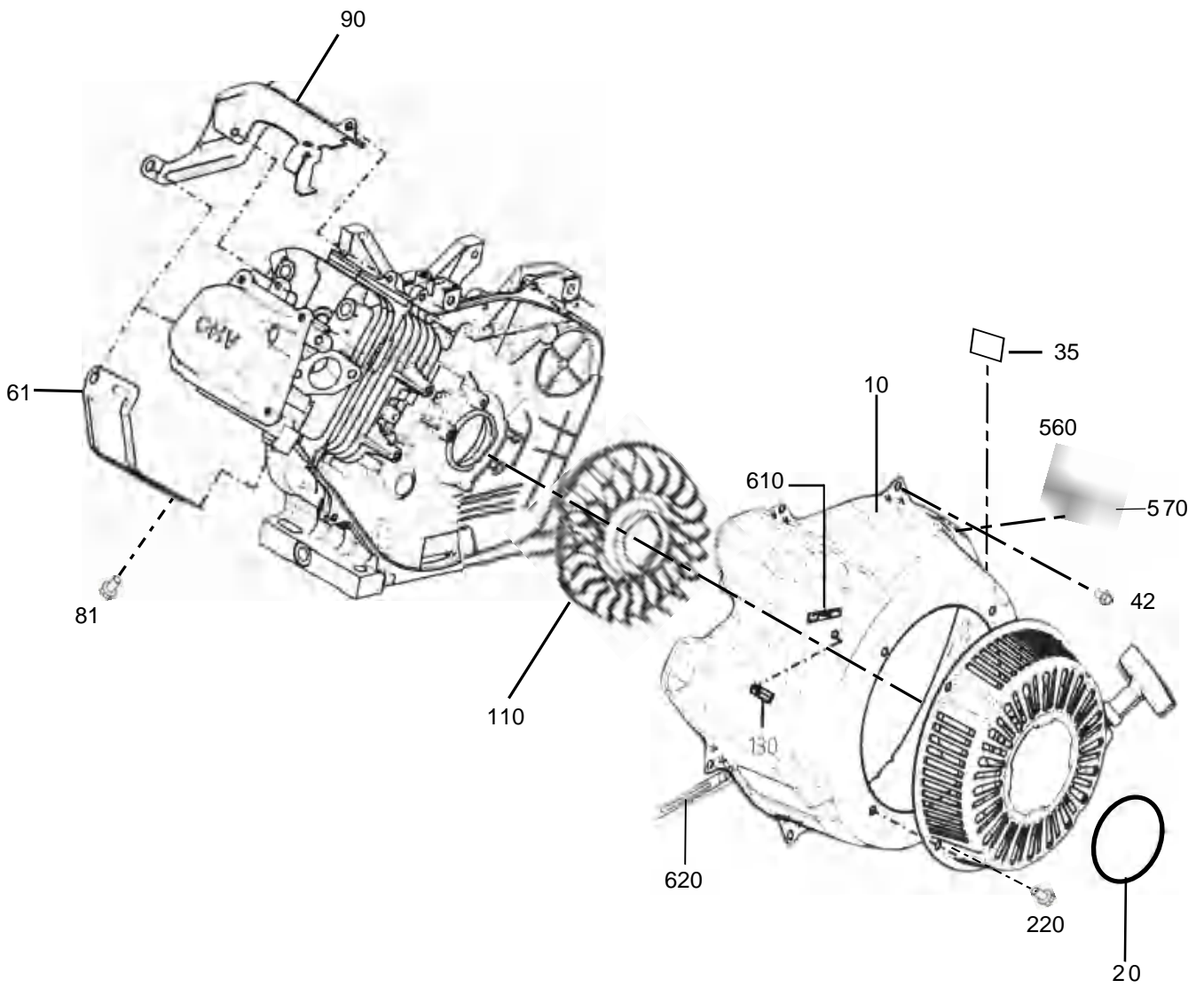

5. 冷却, 启动组·····COOLING, STARTING

指示序号 REF.NO.	零部件代号 PART NUMBER	零部件名称 PART NAME	数量 QTY	备注 REMARKS	图示代号 FIG.NO.
10	40D-51201-H1	导风罩组件 BLOWER HOUSING CP	1		500
20	X73-20051-70	标签 (启动器) LABEL(TARADE MARK)	1		500
35	40D-91872-H3	标签 (铭牌) LABEL(ENGINING NAME)	1		500
42	20F-00600-21	法兰螺栓 FLANGE BOLT	5	M6X12L	500
61	40D-52701-H3	气缸挡板 2 CYLINDER BAFFLE2	1		500
81	20F-13061-60	螺栓/平垫组合 BOLT AND WASHER AY	3	M6X14L	500
90	40D-52602-H3	气缸挡板 1 CYLINDER NAFFLE 1	1		500
110	40D-54101-H3	冷却风扇 COOLING BLOWER	1		500
130	21J-59908-03	油管固定夹 CLAMP(HOSE)	1		500
		油管固定夹 CLAMP(HOSE)	1	长油箱用	500
220	20F-00600-10	法兰螺栓 FLANGE BOLT	4	M6X8L	500
560	X66-00005-10	点火开关 SWITCH AY	1		500
570	20F-00400-90	自攻螺钉 TAPPING SCREW	2		500
610	277-96107-J3	标签 (高-低速) LABEL(H-LOW)	1		500
620	056-60002-50	夹子 CLAMP	1		500

5. 冷却, 启动组..... COOLING, STARTING

FIG.520

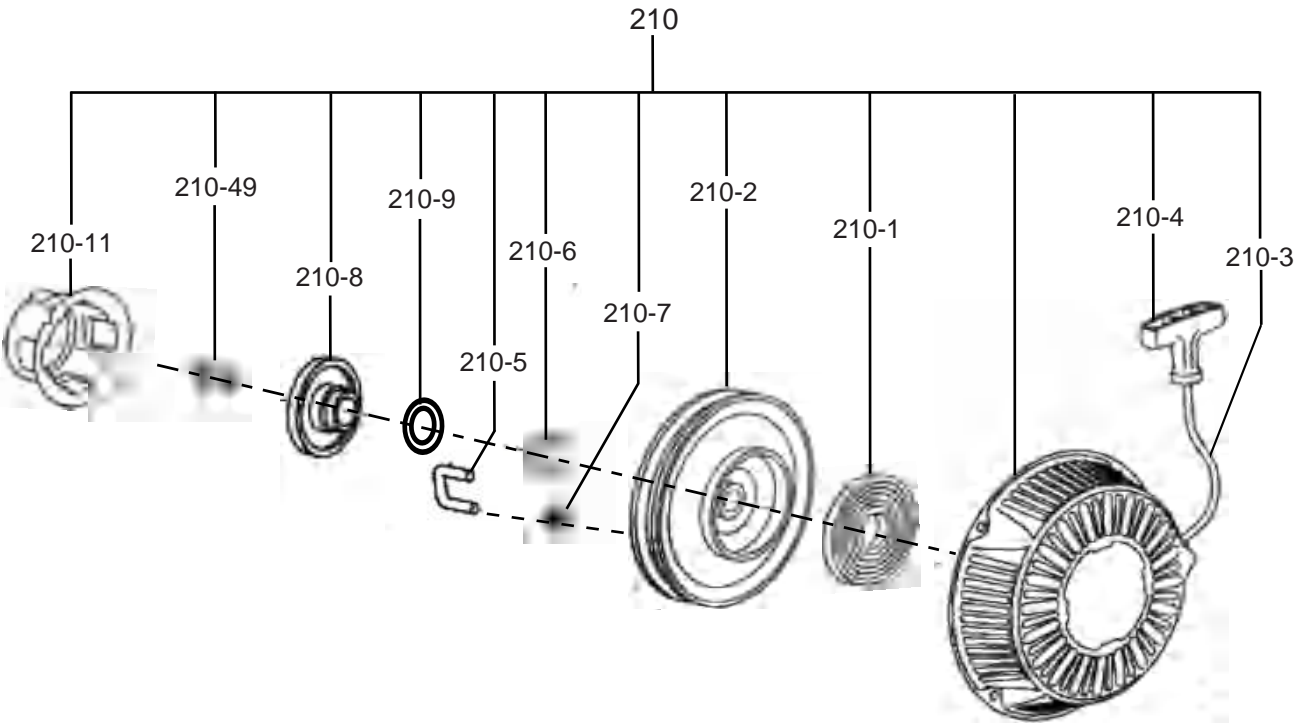

5. 冷却, 启动组..... COOLING, STARTING

指示序号 REF.NO.	零部件代号 PART NUMBER	零部件名称 PART NAME	数量 QTY	备注 REMARKS	图示代号 FIG.NO
210	40D-50101-H0	反冲启动器组合 RECOIL STARTER AY	1		520
-1	22D-50155-H8	卷簧 SPIRAL SPRING	1		520
-2	40D-50120-H8	卷盘 REEL	1		520
-3	40D-50110-H8	启动拉绳 STARTER ROPE	1		520
-4	40D-50100-H8	启动手柄 STARTER KNOB	1		520
-5	22H-50125-H8	棘爪 RATCHET	2		520
-6	40D-50131-H8	导板弹簧 FRICTION SPRING	1		520
-7	40D-50135-H8	复位弹簧 RETURN SPRING	2		520
-8	40D-50140-H8	导向板 RATCHET GUIDE	1		520
-9		止推垫圈	1		520
-11	40D-50145-H8	启动滑车 STARTER PULLEY	1		520
-49	40D-50152-H8	锁紧螺钉 SET SCREW	1		520

6. 燃料供应组 FUEL LUBRICANT

FIG.600

长油箱

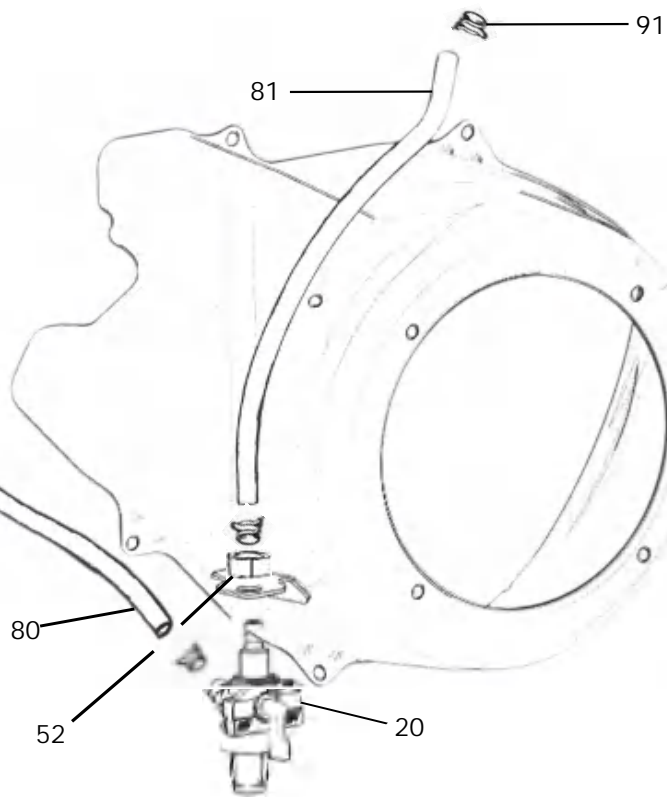
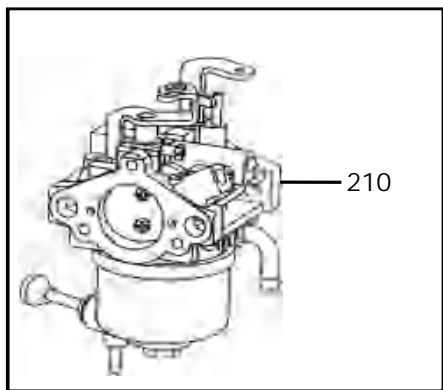
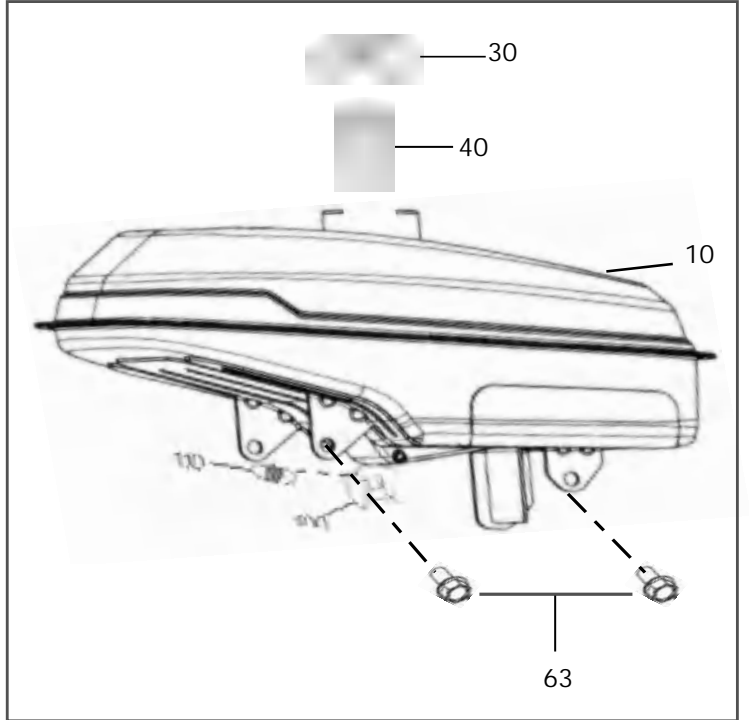
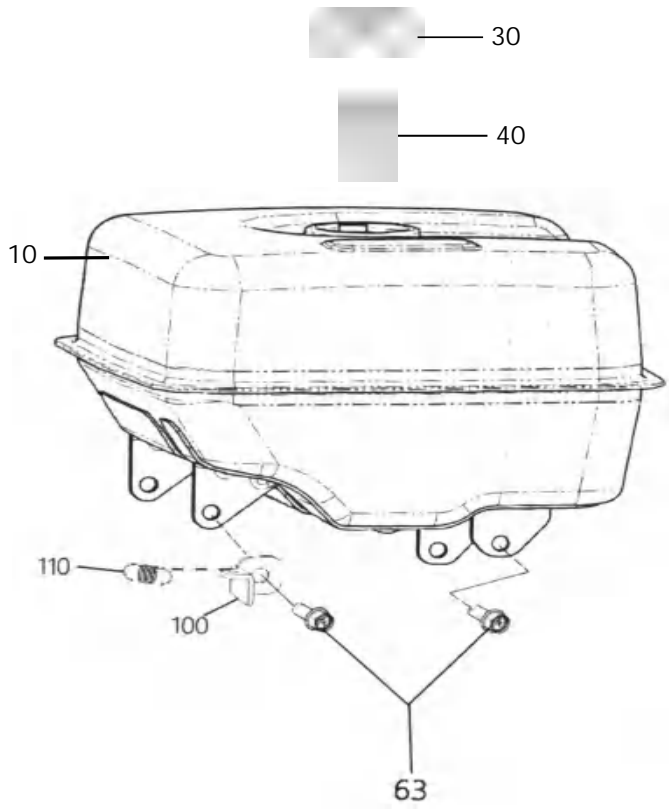

6. 燃料供应组..... FUEL LUBRICANT

指示序号 REF.NO.	零部件代号 PART NUMBER	零部件名称 PART NAME	数量 QTY	备注 REMARKS	图示代号 FIG.NO.
10	40D-60102-H1	油箱组件 FUEL TANK CP	1		600
	40D-60103-H1	油箱组件 FUEL TANK CP	1	红色长油箱 RED FUEL TANK	600
	40D-60104-H1	油箱组件 FUEL TANK CP	1	黑色长油箱 BLACK FUEL TANK	600
20	21J-69901-H0	燃油开关 FUEL STRAINER AY	1		600
30	X43-04300-11	油箱盖组合 FUEL TANK CAP CP	1		600
	X43-04300-60	油箱盖组合 FUEL TANK CAP CP	1	长油箱用	600
40	X64-13600-20	燃油滤网 FUEL FILTER	1		600
52	X17-31200-30	螺母 NUT	1		600
63	X11-00805-00	法兰螺栓 FLANGE BOLT	4	M8X18L	600
80	X85-10623-00	油管（化油器） FUEL PIPE(CARBURETOR AY)	1	L=225	600
81	X85-10623-20	油管（油箱） FUEL PIPE(FUEL TANK)	1	L=305	600
	X85-10624-00	油管（长油箱） FUEL PIPE(FUEL TANK)	1	L=347 长油箱用	600
90	X56-10900-50	油管夹 HOSE PIPE	2		600
91	X56-10900-50	油管夹 HOSE PIPE	2		600
	X56-10900-60	油管夹 HOSE PIPE	2	长油箱用	600
100	22D-47001-H1	支架 BRACKET	1		600
110	22D-47001-H3	复位弹簧 RETURN SPRING	1		600
210	40D-62302-H0	化油器 CARBURETOR AY	1		600

7. 电气系统组 ELECTRIC DEVICE

FIG.700

充电款

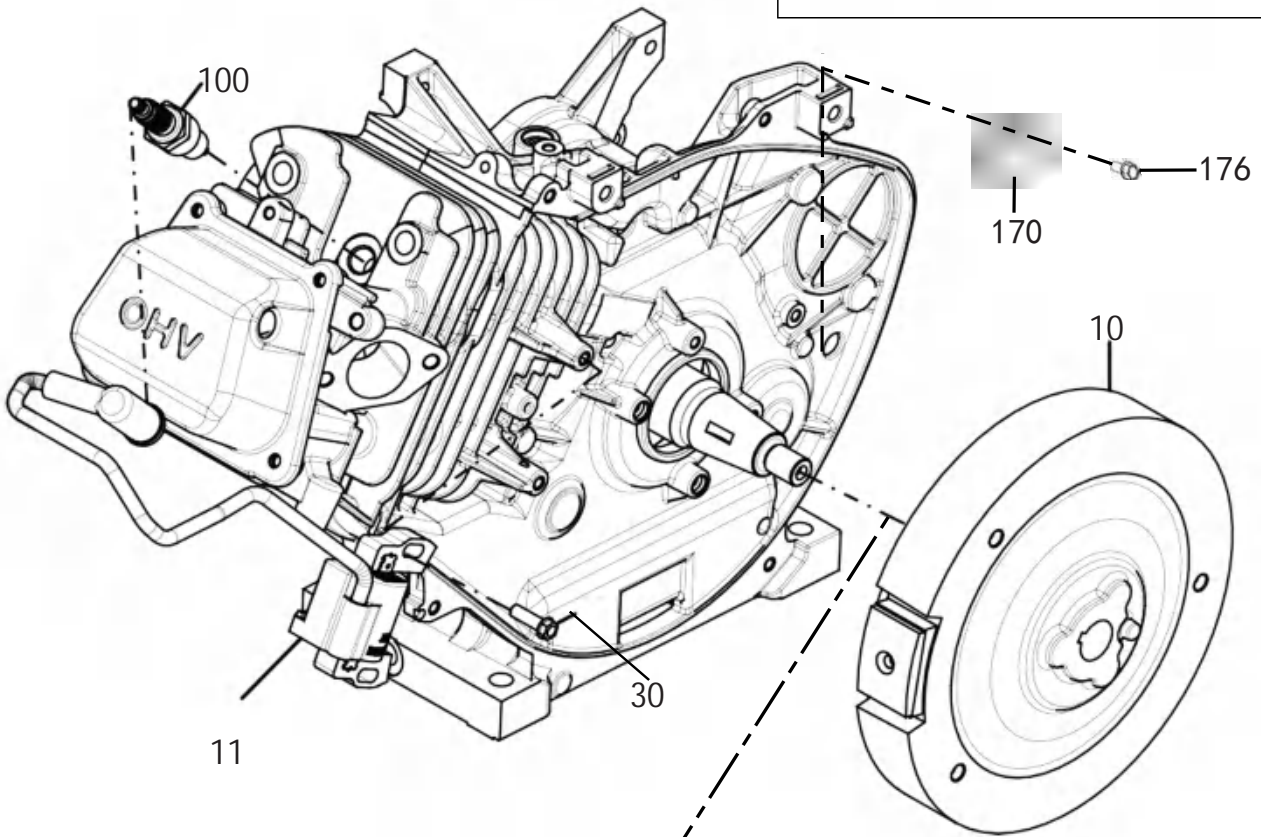
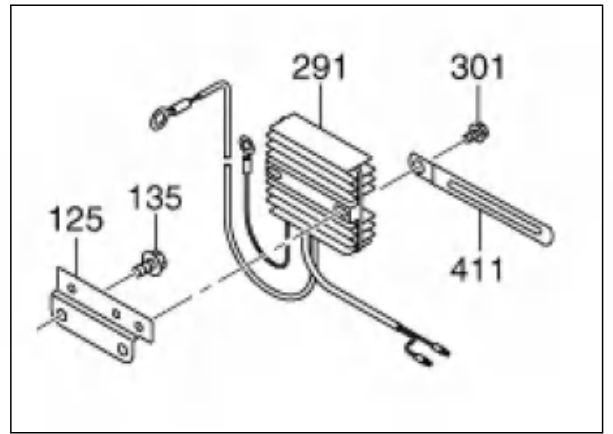

充电款

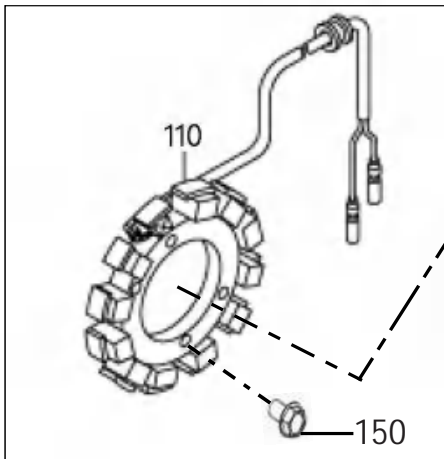

7. 电气系统组·····ELECTRIC DEVICE

指示序号 REF.NO.	零部件代号 PART NUMBER	零部件名称 PART NAME	数量 QTY	备注 REMARKS	图示代号 FIG.NO.
10	40D-79102-H1	飞轮组件 FLYWHEEL CP	1		700
	40D-79104-H1	飞轮组件 FLYWHEEL CP	1	充电款	700
11	40D-79401-H1	点火线圈 IGNITION COIL CP	1		700
30	20F-14062-50	螺栓/平垫组合 BOLT AND WASHER AY	2	M6X20L	700
100	X65-01440-10	火花塞 SPARK PLUG	1		700
110	22D-79306-H1	充电线圈 CHARGE COIL CP	1		700
125	22D-72001-H1	支架组件 BRACKET(REG.)CP	1		700
135	20F-04081-60	法兰螺栓 FLANGE BOLT	2	M8X16L	700
150	X11-00606-70	法兰螺栓 FLANGE BOLT	4	M6X18L	700
291	277-71903-H1	调压器 REGULATOR CP	1		700
301	X11-00606-70	法兰螺栓 FLANGE BOLT	2	M6X18L	700
411	X56-60002-50	夹子 CLAMP	1		700
170	22D-75002-H3	压板(充电线) CLAMP(CHARGE CORD)	1	充电款	700
176	20F-00600-21	法兰螺栓 FLANGE BOLT	1	充电款	700

9. 附件组 ACCESSORIES LABEL

FIG.900

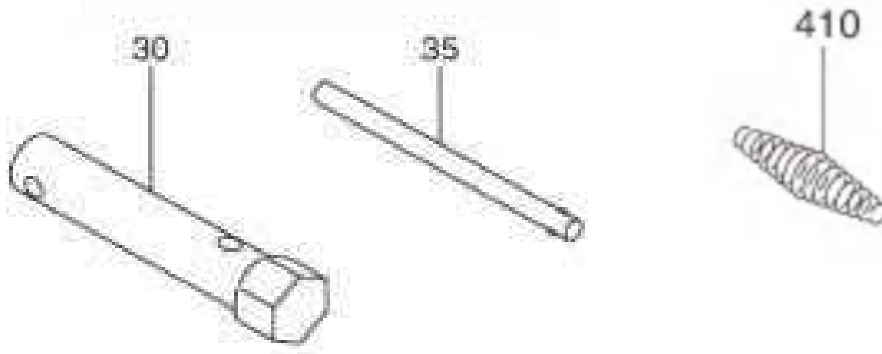

9. 附件组ACCESSORIES LABEL

指示序号 REF.NO.	零部件代号 PART NUMBER	零部件名称 PART NAME	数量 QTY	备注 REMARKS	图示代号 FIG.NO.
30	X71-21400-51	套筒 BOX WRENCH	1		900
35	X71-40900-10	手柄 WRENCH HANDLE	1		900
410	234-46002-13	回位弹簧 RETURN SPRING	1		900